

Introduction

In the real world, many physical processes and measurements have a strong dependence on their local temperature. For example, in ultrasonic distance measurements the speed of the acoustic wave in air varies as a function of temperature (°C) by the relationship:

$$S = 13,044 \sqrt{1 + T/273} \text{ inches/sec}$$

Therefore, the ultrasonic distance measurement system must provide a compensating factor based on the system's ambient temperature. Different transmission media other than air require a different amount of temperature compensation.

Likewise, temperature measurements with a thermocouple are difficult because a thermocouple provides an output voltage that is a function of the difference between the measuring end ("hot end") and the terminal end ("cold end"). Thermocouple output voltage vs temperature tables are based on maintaining the terminal end at 0 °C with an ice bath. Since it is difficult to mount an ice cube on a terminal block, most thermocouple couple measurement systems measure the terminal block temperature, a.k.a. "cold junction", and add a compensating term based on the cold junction temperature. This technique is known as "cold junction compensation". Each thermocouple type (E, J, T, K, S, etc.) requires a different slope of the temperature compensation term.

Another example is a system which requires a reference voltage (or current) with an accurate temperature coefficient:

$$V_{OUT} = V_{REF} * (1 \pm X * T_a)$$

The Intersil ISL21400, Programmable Temperature Slope Voltage Reference, provides the user the ability to generate a software programmable voltage reference (V_{REF}) with a software programmable temperature slope (V_{TS}). The V_{REF} and V_{TS} terms are programmed via an I²C bus with 8 bits of resolution and stored on non-volatile registers. Non-volatile memory storage assures the programmed settings are retained on power-down, eliminating the need for software initialization at device power-up. Low supply current of 200µA and small package size (8 Ld MSOP) make the ISL21400 ideal for small battery operated systems.

Why the ISL21400?

It is not difficult to find voltage references with a fixed output voltage; likewise, there are many different types of temperature sensors. What is unique about the Intersil ISL21400, Programmable Temperature Slope Voltage Reference is the combination of a voltage reference and temperature sensor that allows programming both the output voltage and the temperature slope.

Voltage references can range from the inexpensive, such as the ISL60002 to high accuracy (0.5%) and low drift (2ppm/°C), such as the ISL21007. However, the output voltage is fixed to a factory set initial value (1.2, 2.5, 3.3, etc), and there is no way to change the output voltage. By their very nature and design, the output voltage variations are extremely low because that is the job of a voltage reference.

There are many different types of temperature sensors; four of the most popular available to the design engineer are summarized in the following chart.

SENSOR	ADVANTAGES/DISADVANTAGES
Thermocouple	Operate over a very wide temperature range; difficult to interface due to their low level output voltage and need for cold junction compensation; poor initial accuracy; non-linear output voltage
RTD	Operate over a wide temperature range; requires signal conditioning circuits to obtain an output voltage; very accurate; non-linear resistance vs temperature curve
Thermistor	Inexpensive, small size, narrow temperature range; requires signal conditioning circuits to obtain an output voltage; non-linear resistance vs temperature curve
IC Based	Very accurate; direct output voltage, output current, or digital bus (I ² C); narrow temperature range; fixed output format

Not shown on this chart is the fact that each of these temperature sensors have a fixed output format (mV/ °C, mV/ °F, Ω/°C, digital code/°C, etc.), and in order to change the format, a different device must be selected (ie, J type thermocouple vs K type, or LM35 vs LM34, etc.).

Notice that most of the temperature sensors exhibit a non-linear output response vs temperature which require complex linearizing techniques to obtain a usable output signal.

Block Diagram

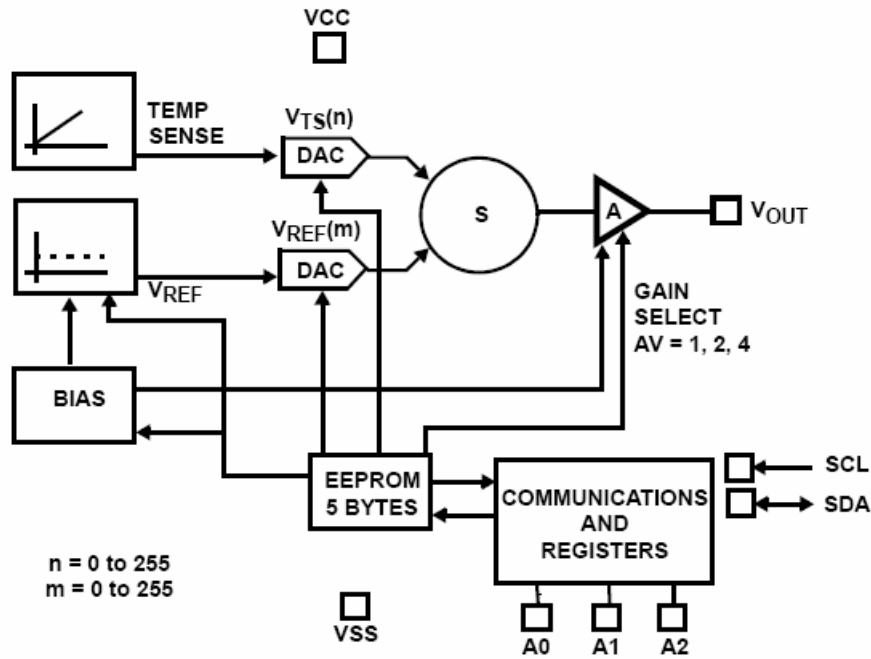

FIGURE 1.

ISL21400 Theory of Operation

Note: Refer to the Block Diagram.

The Intersil ISL21400, Programmable Temperature Slope Voltage Reference provides a programmable output voltage, V_{OUT} which combines both a temperature independent term (V_{REF}) and a temperature dependent term (V_{TS}). The temperature independent term uses a bandgap voltage reference, and the temperature dependent term uses a Proportional To Absolute Temperature (PTAT) reference for the temperature sensor. Both V_{REF} and V_{TS} voltage sources are scalable using two 8 bit non-volatile DACs via the I2C serial bus and summed together for the output voltage, V_{OUT} . The output of the summer circuit goes into a Programmable Gain Amplifier (PGA) which provides programmable gain of 1, 2, 4 via the I2C serial bus. The resulting output voltage can be programmed from 0V to 4.8V and has a programmable Temperature Slope (TS).

The output voltage, V_{OUT} can be programmed as shown in Equation 1:

$$V_{OUT} = AV \times V_{REF} \times (N/255) + AV \times V_{TS} \times (2M - 255) \quad (EQ. 1)$$

where:

$$V_{REF} = 1.200V$$

$$V_{TS} = -2.1mV/^\circ C * (T - 25^\circ C)$$

T = Device temperature, °C

N = 8 to 255, Register 0, Programmed via the I2C serial bus

M = 0 to 255, Register 1, Programmed via the I2C serial bus

$A_V = 1, 2, 4$ Register 2, Programmed via the I2C serial bus

The DAC registers are non-volatile such that the values are restored during the V_{CC} power-up cycle of the ISL21400. There are two additional 8 bit non-volatile registers (Register 4, 5) and one 6 bit non-volatile register (Register 2) in the ISL21400 for general purpose storage needs such as board serial number. The register table is shown in Table 1:

TABLE 1. REGISTER TABLE

REGISTER	DESCRIPTION	ASSIGNED BITS
0	V_{REF} setting (N value)	D0 to D7
1	V_{TS} setting (M value)	D0 to D7
2	A_V setting, 1, 2, 4	D0, D1
	General purpose storage	D2 to D7
3	General purpose storage	D0 to D7
4	General purpose storage	D0 to D7

Communications for programming the ISL21400 is provided via the I2C serial bus and supports a bidirectional bus

oriented protocol. The protocol defines any device that sends data onto the bus as a transmitter and the receiving device as the receiver. The device controlling the transfer is the master and the device being controlled is the slave. The master always initiates data transfers and provides the clock for both transmit and receive operations. Therefore, the ISL21400 operates as a slave device in all applications. A complete technical description and programming information of the ISL21400 I²C serial bus can be found in the ISL21400 data sheet.

Features

Programmable Output Voltage (V_{OUT}) up to 4.8V or $V_{CC} - 0.1V$

The internal voltage reference, V_{REF} of the ISL21400 is fixed at 1.200V with a bandgap reference. Under software control via the I²C serial bus, the V_{REF} DAC programs its output voltage from 0.100V to 1.200V such that:

$$V_{DAC} = V_{REF} * N/255,$$

where N is programmed from 0 to 255 (EQ. 2)

$$V_{DAC} = 1.200 * N/255$$

The output of the V_{REF} DAC, V_{DAC} goes into the programmable gain amplifier which can be set for a gain of 1, 2, or 4 via the I²C serial bus. Therefore, without considering the programmable temperature slope contribution, the overall output voltage, V_{OUT} for the ISL21400 is shown in Equation 3:

$$V_{OUT1} = AV * V_{REF} * (N/255) \quad (EQ. 3)$$

Programmable Temperature Slope (V_{TS}) of $\pm 8.4mV/^\circ C$

The internal voltage sensor, V_{TS} of the ISL21400 is fixed at $-2.1mV/^\circ C * (T - 25)$. Under software control via the I²C serial bus, the V_{TS} DAC programs its output voltage from $-2.1mV/^\circ C$ to $+2.1mV/^\circ C$ such that:

$$V_{DAC} = V_{TS} * (2M - 255) / 255, \quad (EQ. 4)$$

where M is programmed from 0 to 255

$$V_{DAC} = -2.1mV/^\circ C * (T - 25) * (2M - 255) / 255 \quad (EQ. 5)$$

The output of the V_{TS} DAC, V_{DAC} goes into the programmable gain amplifier which can be set for a gain of 1, 2, or 4 via the I²C serial bus. Therefore, without considering the V_{REF} contribution, the overall output voltage, V_{OUT} for the ISL21400 is shown in Equation 6:

$$V_{OUT2} = AV * (-2.1mV/^\circ C) * (T - 25) * (2M - 255) / 255 \quad (EQ. 6)$$

The ISL21400 output voltage, V_{OUT} , is the summation of the programmable reference voltage, V_{OUT1} and the programmable temperature slope, V_{OUT2} such that:

$$V_{OUT} = V_{OUT1} + V_{OUT2}$$

$$V_{OUT} = AV * V_{REF} * (N/255) + AV * V_{TS} * (2M - 255) / 255 \quad (EQ. 7)$$

$$V_{OUT} = AV * 1.2 * (N/255) + AV * (-2.1mV/^\circ C) * (T - 25) * (2M - 255) / 255$$

This discussion assumes the ISL21400 is operating with a +5V supply (V_{CC}) and no output load current. When operating on a lower power supply voltage such as 3.3V and/or increased load current, the maximum V_{OUT} voltage is limited by V_{CC} and the load current as discussed in Paragraph 5, "Output Voltage Considerations" on page 4.

8 Bit Resolution For V_{REF} and V_{TS}

Each of the DACs for the V_{REF} programming and the V_{TS} programming feature 8 bits of resolution which are programmed via the I²C serial bus.

Non-Volatile Storage of Programming Registers

The DAC, programmable gain amplifier, and storage registers are non-volatile such that the values are restored during the V_{CC} power-up cycle of the ISL21400.

Two Uncommitted Registers of 8 Bits of Non-Volatile Storage

There are two 8-bit non-volatile registers (Register 4, 5) and one 6-bit non-volatile register (Register 2) in the ISL21400 for general purpose storage needs, such as board serial number.

Bidirectional Bus Oriented Protocol, I²C Interface, Slave Device

Communication for programming the ISL21400 is provided via the I²C serial bus and supports a bidirectional bus oriented protocol. The ISL21400 operates as a slave device in all applications.

Operating Voltage (V_{CC}) of +2.7V to +5.5V

Low Supply Current of 500 μA

The active supply current is only 500 μA (maximum) operating on a +5V supply, and is reduced to 400 μA (maximum) operating on a 2.7V supply. This allows the ISL21400 to be used in a battery operated system and achieve long battery life.

- 2% total accuracy over the complete V_{CC} and temperature range
- Industrial temperature range, $-40^\circ C$ to $+85^\circ C$, operating
- Very small surface mount MSOP, 8 Lead MSOP package

Design Equations, Procedure and Programming

V_{OUT} and dV_{OUT}/dT Design Equations

The output voltage, V_{OUT} can be programmed as shown in Equation 8:

$$V_{OUT} = AV \times V_{REF} \times N/255 + AV \times V_{TS} \times (2M - 255)/255 \quad (\text{EQ. 8})$$

where:

$$V_{REF} = 1.200V$$

$$V_{TS} = -2.1 \text{ mV}/^\circ\text{C} \times (T - 25^\circ\text{C})$$

T = Device temperature, °C

N = 8 to 255, Register 0, Programmed via the I²C serial bus

M = 0 to 255, Register 1, Programmed via the I²C serial bus

AV = 1, 2, 4 Register 2, Programmed via the I²C serial bus

or,

$$V_{OUT} = AV \times 1.2 \times (N/255) + AV \times (-2.1 \text{ mV}/^\circ\text{C}) \times (T - 25) \times (2M - 255)/255 \quad (\text{EQ. 9})$$

This equation can be broken down into two terms, fixed programmable voltage output and a programmable dependant voltage output. The fixed programmable voltage reference with M = 128 (ie, no temperature slope) is shown in Equation 10:

$$V_{OUT} = AV \times 1.2 \times (N/255) \quad (\text{EQ. 10})$$

or,

$$N = V_{OUT} \times 255 / (AV \times 1.2) \quad (\text{EQ. 11})$$

For example, a 2.052V general purpose voltage reference can be obtained by setting AV = 2, N = 218, and M = 128. The programmable temperature dependant voltage output with N = 0 is:

$$V_{OUT} = AV \times (-2.1 \text{ mV}/^\circ\text{C}) \times (T - 25) \times (2M - 255)/255 \quad (\text{EQ. 12})$$

Taking the first derivative:

$$dV_{OUT}/dT = AV \times (-2.1 \text{ mV}/^\circ\text{C})$$

where VS = -2.1 mV/°C

Solving for M:

$$M = 255 \times (dV_{OUT}/dT + AV \times VS) / (2 \times AV \times VS) \quad (\text{EQ. 13})$$

As shown in Table 2 dV_{OUT}/dT can range from ±2.1 mV/°C to ±8.4 mV/°C, depending on the values of AV and M.

TABLE 2.

AV	MIN dV _{OUT} /dT	MAX dV _{OUT} /dT
	M = 0	M = 255
1	+2.1mV/°C	-2.1mV/°C
2	+4.2mV/°C	-4.2mV/°C
4	+8.4mV/°C	-8.4mV/°C

For example, a 2.052V general purpose voltage reference at +25°C with a temperature coefficient of +3.6 mV/°C can be obtained by setting AV = 2, N = 218, and M = 18.

Output Voltage Considerations

The output drive current capability of the ISL21400 is limited to ±500µA at the rated accuracy, and the output resistance is 5Ω (maximum) so care must be given when driving loads. Additionally, the maximum load capacitance capability is 5000 pF so a buffer amplifier should be used if driving large load capacitance.

While it may seem obvious, it must be noted that the ISL21400 will not generate a proper output voltage that is outside the Output Voltage Swing values shown in Table 3 even though the V_{OUT} design equation (Equation 1) is satisfied.

TABLE 3. OUTPUT VOLTAGE CONSIDERATIONS

Output Resistance, R _{OUT}	5Ω maximum
Output Current, I _{OUT}	500µA
Short Circuit Output Current, I _{sc}	±9mA
Load Capacitance	5000pF, maximum
Output Voltage Swing - Unloaded	VCC - 100mV, Gnd + 100mV
Output Voltage Swing - 500 µA	VCC - 250mV, Gnd + 250mV

The ISL21400 exhibits a non-zero output voltage (VOS) at N = 0 due to the saturation voltage of output amplifier and offset voltages in the DAC and Summer stages as shown in Table4. In a closed loop system these are not important since the VOS error is calibrated out. However, in a high accuracy open loop system, the VOS error can be significant and should be considered as discussed in Appendix A.

TABLE 4.

AV	TYP VOX (mV)
1	76
2	110
3	191

TABLE 5. ISL21400 REGISTER BIT MAP

ADDR	D7 (MSB)	D6	D5	D4	D3	D2	D1	D0 (LSB)
0	V _{REF7}	V _{REF6}	V _{REF5}	V _{REF4}	V _{REF3}	V _{REF2}	V _{REF1}	V _{REF0}
1	TS7	TS6	TS5	TS4	TS3	TS2	TS1	TS0
2	D7	D6	D5	D4	D3	D2	GAIN 1	GAIN 0
3	D7	D6	D5	D4	D3	D2	D1	D0
4	D7	D6	D5	D4	D3	D2	D1	D0

Output Noise Filtering

The ISL21400 output voltage noise is typically 90µV_{p-p} in a 0.1Hz to 10Hz bandwidth with A_V = 1. Adding load capacitance up to 5000pF will only result in marginal improvements in output noise. For high impedance loads, a low pass filter with an R-C network can be added to filter the high frequency noise and preserve DC accuracy.

Open Loop vs Closed Loop Operating Systems

Many of the applications for the ISL21400 are compensating voltages in a closed loop system where in-circuit calibration allows for most accurate operation. From initial calculation to programming to hardware operation, there is usually some error that can be re-calibrated out of a system with the use of production test equipment or an embedded microprocessor. Any initial ISL21400 error source should be calibrated out using this technique.

However, there may be systems where open loop operation and more precision is required. Appendix A describes the calculations for improving the accuracy of the ISL21400 in open loop systems.

Register Descriptions

TABLE 6.

REGISTER	DESCRIPTION	ASSIGNED BITS
0	V _{REF} setting (N value)	D0 to D7
1	V _{TS} setting (M value)	D0 to D7
2	A _V setting, 1, 2, 4	D0, D1
	General purpose storage	D2 to D7
3	General purpose storage	D0 to D7
4	General purpose storage	D0 to D7

I²C Programming (Reference Data Sheet Information)

For applications information on I²C Serial Interface, refer to the ISL21400 data sheet.

Application Circuits

Temperature Compensated Current Source

A simple, yet effective, 2mA current source can be made with a transistor and resistors as shown in the following diagram.

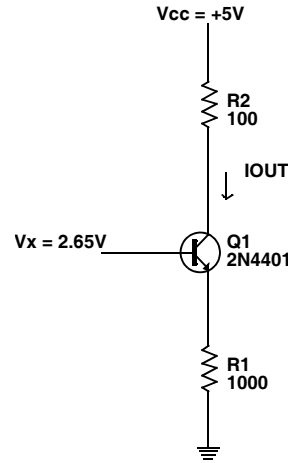

FIGURE 2.

For this circuit, $I_{OUT} = (V_x - V_{be}) / R_1$

$$I_{OUT} = (2.65 - 0.65) / 1000 \text{ (assuming } V_{be} = 0.65V \text{ at } +25^\circ C)$$

$$I_{OUT} = 2.0mA$$

Since a transistor V_{be} has a temperature coefficient of -2.1 mV/°C, the output current will also be temperature dependant.

$$\begin{aligned} dI_{out}/dT &= dV_{be}/dT / R_1 = -2.1 \text{ mV}/^\circ C / 1000 \\ &= -2.1 \mu A/^\circ C \end{aligned}$$

$$\begin{aligned} \text{At } +75^\circ C, I_{OUT} &= 2.0 \text{ mA} - 2.1 \mu A/^\circ C * (75^\circ C - 25^\circ C) \\ &= 2.0mA - 0.105 \text{ mA} = 1.895mA \end{aligned}$$

The ISL21400 can be used to provide V_x = 2.65V with a temperature coefficient of -2.1 mV/C to compensate for the V_{be} temperature coefficient as shown in the following diagram.

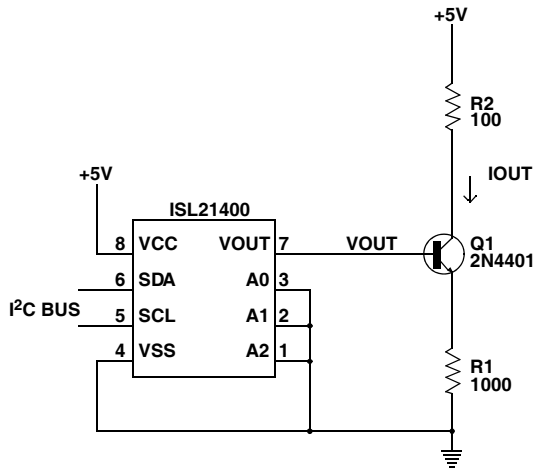

FIGURE 3.

To compensate the temperature drift of Q1's Vbe of $-2.1\text{mV}/^\circ\text{C}$, the ISL21400 provides a 2.65V reference with a temperature coefficient of $-2.1\text{mV}/^\circ\text{C}$ by appropriate settings of AV, N, and M as follows:

$$V_{OUT} = AV \times 1.2 \times (N/255) \quad (\text{EQ. 14})$$

$$N = V_{OUT} \times 255 / (AV \times 1.2)$$

Set $AV = 4$ since a 2.65V output is required

$$N = 2.65 \times 255 / (4 \times 1.2)$$

$$N = 140.78$$

Use $N = 141$

$$dV_{OUT}/dT = AV \times Vs \times (2M - 255) / 255$$

where $Vs = -2.1\text{mV}/^\circ\text{C}$

Solving for M:

$$M = 255 \times (dV_{OUT}/dT \times AV \times Vs) / (2 \times AV \times Vs)$$

$$M = 255 \times ((-2.1\text{mV}/^\circ\text{C} \times 4 \times -2.1\text{mV}/^\circ\text{C}) / (2 \times 4 \times -2.1\text{mV}/^\circ\text{C}))$$

$$M = 159.4$$

Use $M = 159$

$$V_{OUT} = AV \times 1.2 \times (N/255) + AV \times (-2.1\text{mV}/^\circ\text{C}) \times (T - 25) \times (2M - 255) / 255$$

$$V_{OUT} = 4 \times 1.2 \times (141/255) + 4 \times (-2.1\text{mV}/^\circ\text{C}) \times (T - 25) \times (2 \times 159 - 255) / 255$$

$$V_{OUT} = 2.65 - 2.1\text{mV}/^\circ\text{C} \times (T - 25^\circ\text{C})$$

For this circuit, $I_{OUT} = (V_{OUT} - V_{be}) / R1$

$$V_{be} = 0.65 + (-2.1\text{mV}/^\circ\text{C}) \times (T - 25^\circ\text{C})$$

$$I_{OUT} = [2.65 - 2.1\text{mV}/^\circ\text{C} \times (T - 25^\circ\text{C}) - (0.65 - 2.1\text{mV}/^\circ\text{C} \times (T - 25^\circ\text{C}))] / R1$$

$$I_{OUT} = (2.65 - 0.65) / R1$$

$I_{OUT} = 2.0\text{mA}$ independent of temperature

Temperature Controlled Current Source

A much more accurate current source can be made by using an op amp in a feedback loop to tightly regulate the output current controlled by an input voltage source as shown in Figure 4.

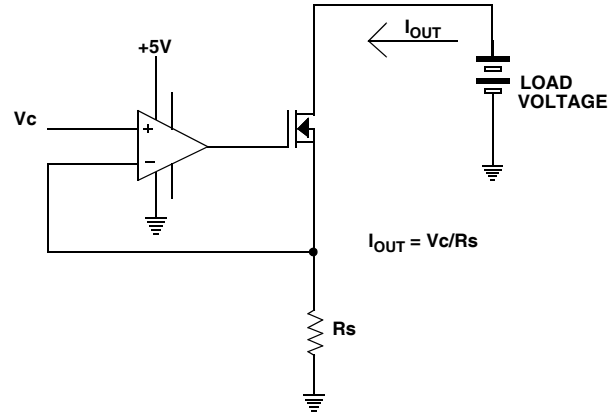

FIGURE 4.

If the ISL21400 is used for the source of the control voltage, Vc , the output current and output current temperature coefficient can be programmed via the I²C bus with the N and M registers as shown on the schematic in Figure 5.

$$Vx = AV \times V_{REF} \times (N/255) + AV \times V_{TS} \times (2M - 255) / 255$$

$$\text{Set } AV = 1 \quad (\text{EQ. 15})$$

$$Vx = 1.2 \times (N/255) - 2.1\text{mV}/^\circ\text{C} \times (T - 25^\circ\text{C}) \times (2M - 255) / 255$$

Resistors R1 and R2 divide down the ISL21400 output voltage to set the full scale output current based on the value of R_s .

$$Vy = Vx \times R_2 / (R_1 + R_2)$$

$$Vy = Vx \times 13.7\text{k} / (52.3\text{k} + 13.7\text{k}) \quad (\text{EQ. 16})$$

$$Vy = Vx \times .208$$

The op amp feedback loop forces $I_{OUT} \times R_s = Vy$

$$I_{OUT} = Vy / R_s = Vx \times 0.208 / R_s$$

$$I_{OUT} = Vx \times 0.208 / .05$$

$$I_{OUT} = 4.16 Vx \quad (\text{EQ. 17})$$

$$I_{OUT} = 4.16 \times [1.2 \times (N/255) - 2.1\text{mV}/^\circ\text{C} \times (T - 25^\circ\text{C}) \times (2M - 255) / 255]$$

$$I_{OUT} = 5.0 \times (N/255) - 8.75\text{mA}/^\circ\text{C} \times (T - 25^\circ\text{C}) \times (2M - 255) / 255$$

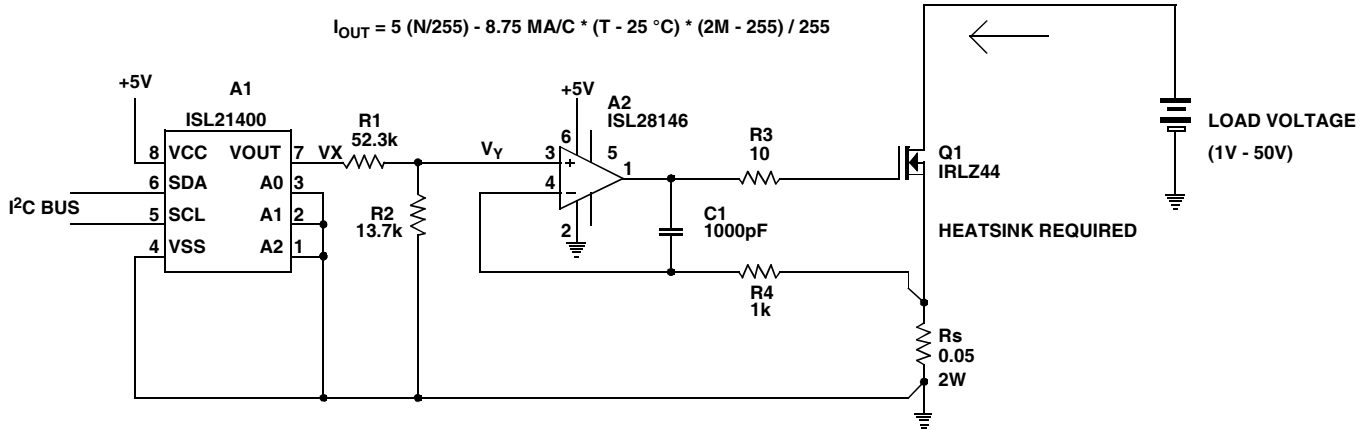

FIGURE 5. 8-BIT ADJUSTABLE CURRENT SOURCE W/ADJUSTABLE TEMP. CONTROL

The output current at +25 °C and the output current temperature coefficient can both be programmed via the I²C bus from values of 150mA to 5A (N = 8 to 255) with a temperature slope ranging from - 8.75 mA/ °C to + 8.75 mA/ °C (M = 0 to 255).

RFPA LDMOS Bias

LDMOS transistors are used for RF Power Amplification in numerous applications from point-to-multipoint communications to radar. The most pervasive application is in cell phone base stations. These RF Power Amplifiers (RFPA) provide from 5W to over 200W of output power per channel, and require very good linearity to maximize the data throughput in a given channel. The main point to consider is that linearity is the DC biasing of the LDMOS transistor for optimal drain current for a given power output. This bias needs to be held constant over temperature and time. Typically the target accuracy for bias current over temperature is ±5% but ±3% is much more desirable for a high performance design.

A simplified circuit of an LDMOS amplifier bias circuit is shown in Figure 6.

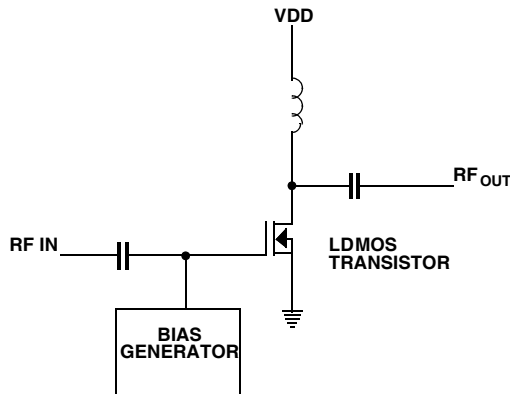

FIGURE 6. SIMPLIFIED CIRCUIT

The DC Bias on these amplifiers is set by applying a DC voltage to the gate (V_{GS}) and monitoring the Drain current (I_{DD}). Ideally, this I_{DD} will be constant over temperature, but since the V_{GS} of LDMOS amplifier devices varies with temperature, some type of temperature compensation is required. One method of setting this DC bias involves using an adjustable reference, DAC, or Digital potentiometer combined with a temperature compensation source, such as a transistor V_{BE} multiplier. This solution can work well, but getting tight temperature compensation can be problematic since the V_{BE} junction temperature characteristic for production transistors will vary. Also, the V_{GS} tempco for LDMOS amplifiers will vary with I_{DD} . The result is that there are variations in V_{BE} junction characteristics as well as the LDMOS characteristics. For optimal temperature compensation, in-circuit adjustments need to be made for both the temperature compensation as well as the V_{GS} bias itself.

A new way to bias an LDMOS amplifier is presented in Intersil Application Note AN1385, "LDMOS Transistor Bias Control in Base Station RF Power Amplifiers Using Intersil ISL21400" which is summarized in the following. This Application Note shows using the ISL21400 to set both the DC bias level and temperature compensation for the VGS bias, and is shown in the following schematic in Figure 7.

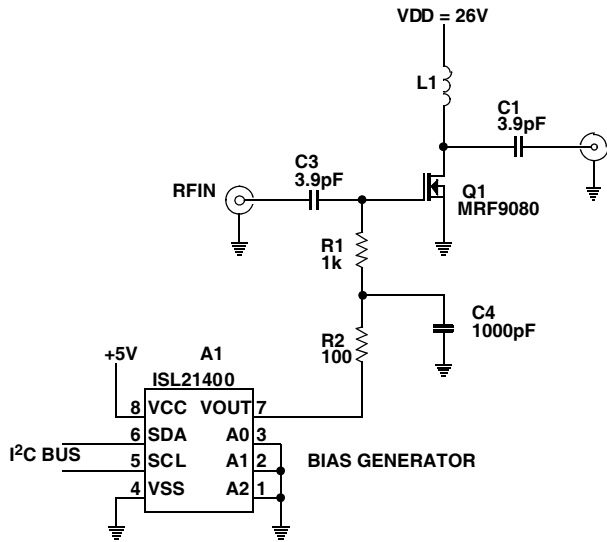

FIGURE 7.

In this circuit, the N-channel LDMOS transistor gate has approximately a $-2.8\text{mV}/^\circ\text{C}$ temperature coefficient from -10°C to $+85^\circ\text{C}$. A constant bias drain current is desired, with a target V_{GS} range derived from the data sheet of 2.5V to 3.5V at $+25^\circ\text{C}$. The ISL21400 bias generator sets the DC bias level to 3.0VDC which is the midpoint of the V_{GS} range.

To determine the N register value:

$$V_{OUT} = A_V * 1.2 * (N/255)$$

A_V must be 4 for an output voltage of 3.0V.

$$N = V_{OUT} * 255 / (4 * 1.2) \tag{EQ. 18}$$

$$N = 3.0 * 255 / (4 * 1.2)$$

$N = 159$ decimal

To determine the M register value:

$$dV_{OUT}/dT = -2.8 \text{ mV}/^\circ\text{C}$$

$$dV_{OUT}/dT = A_V * (-2.1\text{mV}/^\circ\text{C}) * (2M - 255) / 255 \tag{EQ. 19}$$

$$-2.8\text{mV}/^\circ\text{C} = 4 * (-2.1\text{mV}/^\circ\text{C}) * (2M - 255) / 255$$

$M = 170$ decimal

One thing to note in this design or any that requires temperature compensation is the mechanical properties of the board mounting and the cooling system. In this example, airflow over the LDMOS device and the temperature sensor was limited, which enhanced the resulting compensation. Also, the sensor was surface mounted with conductive grease next to the LDMOS device. In many designs, precise control over placement and airflow is not possible, but since calibration takes place *after* the assembly of the unit, these

effects can be minimized as long as the final installation is similar to the calibration conditions. LDMOS amplifiers also have a characteristic I_{DD} drift over time (drain current reduces for a given V_{GS}), as well as temperature. This can be addressed with recalibration of the ISL21400 bias generator via system level software via the I²C bus.

Thermocouple Input Cold Junction Compensation

Thermocouples are the industry standard temperature sensor for measuring a wide range of temperatures from -250°C to $+2300^\circ\text{C}$. The four most popular thermocouple types are shown in the table below; however, any time two dissimilar metals are placed in contact, a thermocouple is created via the Seebeck Effect.

TABLE 7.

TYPE	TEMPERATURE RANGE		VO at Tmin (mV)	VO at Tmax (mV)	dVo/dT from 0° to +50°C (µV/°C)
	Minimum	Maximum			
E	-200°C	$+900^\circ\text{C}$	-8.83	68.79	61.00
	-328°F	$+1652^\circ\text{F}$			
J	0°C	$+750^\circ\text{C}$	0.00	42.30	51.70
	$+32^\circ\text{F}$	$+1382^\circ\text{F}$			
K	-200°C	$+1250^\circ\text{C}$	-5.89	50.64	40.50
	-328°F	$+2282^\circ\text{F}$			
T	-250°C	$+350^\circ\text{C}$	-5.60	17.82	40.70
	-328°F	$+662^\circ\text{F}$			

Thermocouples present several unique challenges when interfacing them to a real world measurement system.

1. Thermocouples generate a very low output voltage that must be amplified with a high gain amplifier. Each thermocouple type requires a different gain when interfacing to a A/D Converter with a fixed full scale voltage, $V_{FS}/V_{O_{MAX}}$.
2. Thermocouples do not generate an absolute voltage that is proportional to temperature. Instead, they generate a voltage that is a relative voltage that is the proportional to the temperature difference between the "hot" end and the "cold" end. All thermocouple tables showing output voltage vs temperature are for the "cold" end placed in an ice bath at 0°C . Since it is very impractical to place an ice bath on a PCB, electronic cold junction compensation is used. Each thermocouple type requires a cold junction compensation rate, dV_{cjc}/dT .
3. The output voltage of a thermocouple is non-linear, and is dependant on the type of thermocouple. Linearization is most often done with diode break-point techniques or via

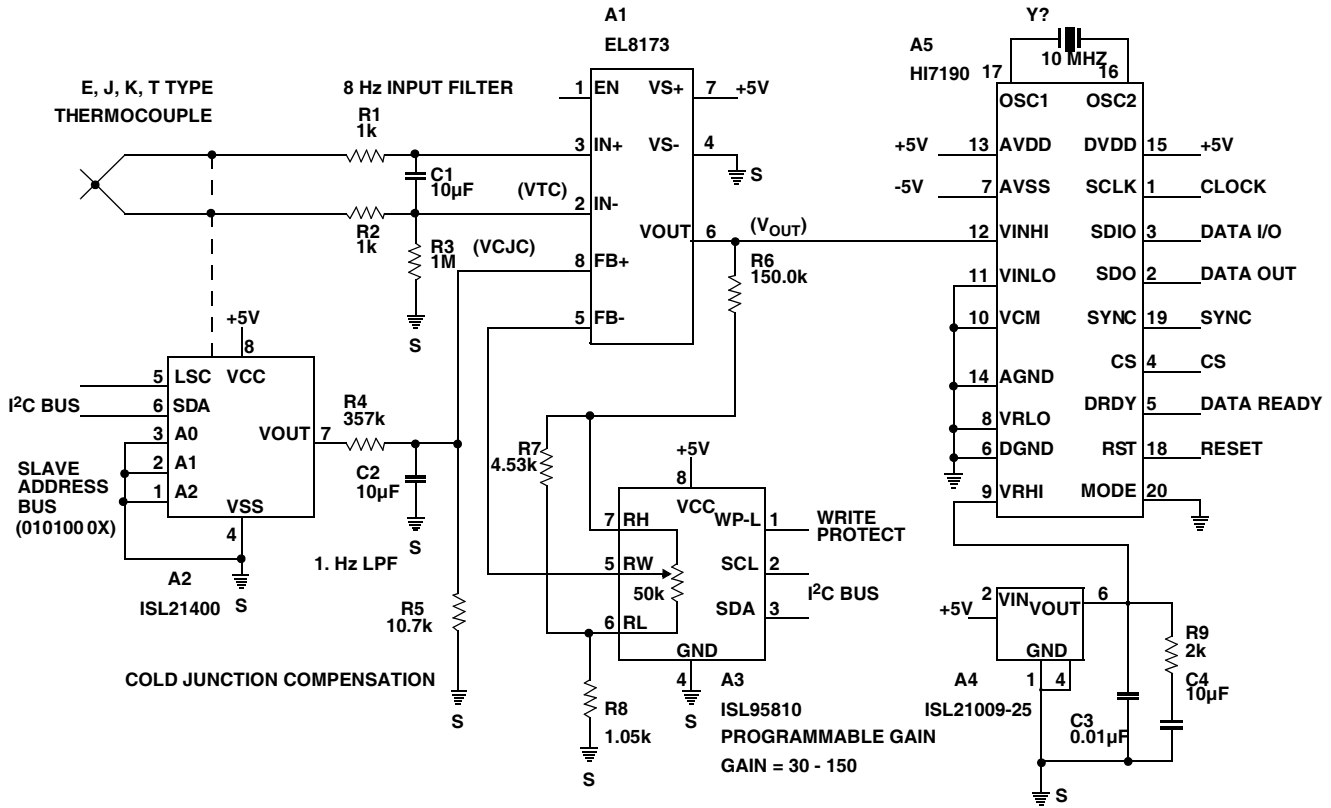

FIGURE 8.

microprocessor software, and is not covered in this Application Note.

digital pot for each of the thermocouple types as shown in Table 9.

The circuit shown in Figure 8 uses the unique features of the Intersil ISL21400 to provide a programmable cold junction compensation voltage for each of the standard thermocouple types.

An Intersil EL8173 Instrumentation Amplifier is used to simplify the Thermocouple interface to a high resolution A/D Converter (A5). A programmable gain digital pot (A3) and the ISL21400 programmable temperature sensor (A2) allows digital selection of the four most popular thermocouple types; E, J, K, and T.

Cold junction compensation is programmed via the I²C bus by the ISL21400 programmable reference and temperature sensor (A2) and resistor divider network R4 and R5 according to Table 8 with AV = 1 and N register = 0.

TABLE 8.

TC TYPE	V _{cjc} (μV/°C)	M REGISTER
E	61.0	0
J	51.7	20
K	40.5	43
T	40.7	43

The programmable gain amplifier (A1, A3) provides a gain from 30 to 150 that is programmed via the I²C bus with the

TABLE 9.

TC Type	MAXZ V _{OUT}	GAIN	D-POT CODE ₁₀
E	68.97mV	36.34	195
J	42.30mV	59.10	094
K	50.64mV	49.37	126
T	17.82mV	140.3	000

Low pass filters (R1, R2, C1) provide noise filtering with a 8 Hz cut-off frequency. R3 is used for a return current path for the EL8173's input bias current. An additional low pass filter (R4, R5, C2) attenuates the ISL21400's output noise voltage with a 1.6Hz cut-off frequency.

A high resolution (24-bit) Sigma-Delta A/D Converter, HI7190, converts the output of the instrumentation amplifier, EL8173, with a full scale input voltage of 2.5V set by the ISL21009 -2.5 voltage reference.

The non-zero output voltage (VOS) of the ISL21400 at N = 0 results in an offset in the temperature reading since for cold junction compensation the compensating voltage must be zero voltage at 0°C.

In this thermocouple input application circuit, the output of the ISL21400 is divided by 34.4 by a resistor divider (357k, 10.7k) which divides the VOS by the same amount.

$$VFB+ = VOS / 34.4$$

$$VOS = 76mV \text{ (Measured value)}$$

$$Verror = 76mV/34.4 = 2.21mV$$

$$Terror = Verror/dV/dT \text{ of TC} \tag{EQ. 20}$$

$$Terror = 2.2mV/ 51.7 \mu V/C \text{ For J-type TC}$$

$$Terror = +42.5^{\circ}C$$

Table 10 shows the temperature error for each TC type and a VOS typical value of 76mV and maximum value of 100mV. Microprocessor software must subtract the Temperature Error from the actual reading by measuring the actual ambient temperature.

TABLE 10.

TC Type	dV/dT (μV/C)	TEMPERATURE ERROR	
		VOS = 76mV (C)	VOS = 100mV (C)
E	61.0	36.2	47.7
J	51.7	42.7	56.2
K	40.5	54.6	71.8
TC TYPE	40.7	54.3	71.4

Using the Intersil ISL21400, Programmable Temperature Slope Voltage Reference to Optimize DVD Write

A DVD writer uses one of two laser colors - traditional red (650nm) and newer blue (405nm) known as Blue-ray. The laser is used to melt small marks into the underside of the DVD to record the information. The smaller the marks, the more marks (and information) can be stored. The writing process generates a sizable amount of heat that makes the laser energy less effective at creating distinct marks, which

creates signal jitter. Therefore, thermal feedback with a simple thermistor to monitor temperature is included in DVD writers to optimize write time. The drawback to this design choice is that the output voltage of a thermistor is not linear with respect to temperature and the feedback system must account for the nonlinearities to be able to operate at a wider range of temperatures.

Whether a red or Blue-ray optical unit is employed, continuous recording times for a television episode or a movie can be sizable. As expected, the current trends crunch more data in smaller spaces, so the Blue-ray system, where the wavelength is 37% smaller, is preferred. With more data to store (HDTV), Blue-ray systems commonly require longer write times which cause the temperature to increase more than +60°C, which can harm the laser. In addition, there will be shift in the laser output wavelength due to the change in temperature. The system must adapt to maintain quality marking and protect the laser with this increase in temperature by temporarily disabling the laser, changing the laser current, or activating a cooling fan. A better solution can minimize the disabled time, as well as the need for a cooling fan by accurately monitoring the temperature, adjusting the laser current to maintain the proper wavelength, and intelligently controlling the fan as needed.

Figure 9 shows the Intersil ISL21400, Programmable Temperature Slope Voltage Reference in place of a thermistor in a typical DVD writer application. Since the Intersil ISL21400, Programmable Temperature Slope Voltage Reference is a programmable device, the output voltage range can be linearized as well as matched to the operating temperature range of the system. The programmable nature also provides other system design aids, such as matching the full scale voltage input range of the ADC (a typical load in DVD systems, see Figure 9) and maximizing sensitivity. In addition to the advantages listed previously, the ISL21400 includes 2 bytes of EEPROM that can be used for storage of laser diode calibration, serial numbers, manufacturing codes or model numbers. This would eliminate the need for assemblers to manually enter this information.

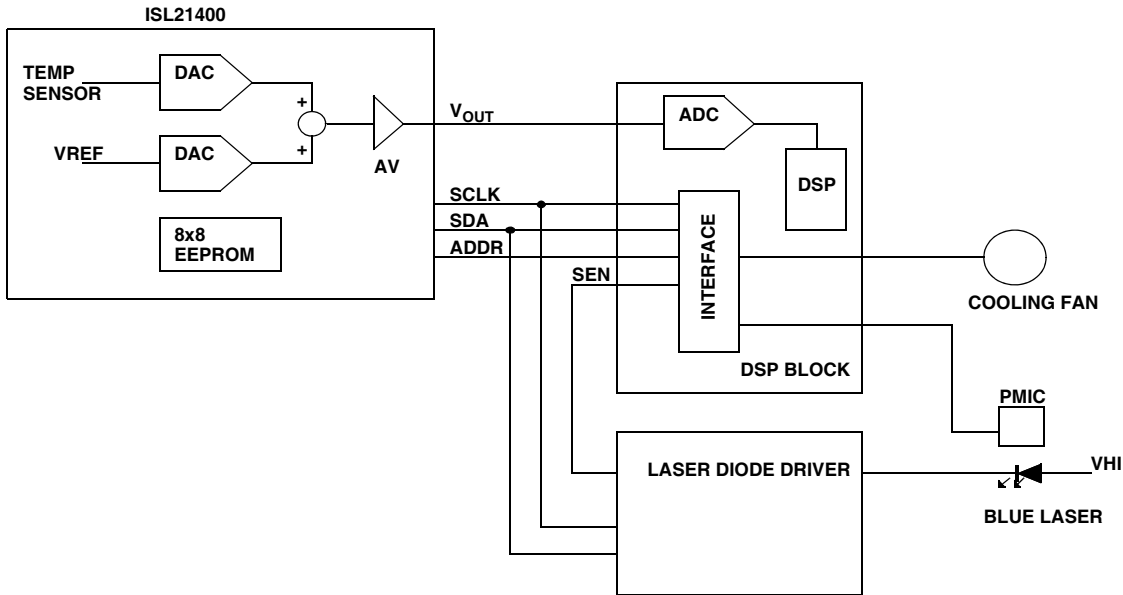

FIGURE 9. BLOCK DIAGRAM FOR LASER-WRITING USING THE INTERSIL ISL21400 PROGRAMMABLE TEMP - SLOPE VREF

Variable DAC Reference

The Intersil ISL21400, Programmable Temperature Slope Voltage Reference can easily be used to provide a programmable reference voltage for either a Digital to Analog Converter (DAC) or an Analog to Digital Converter. In the case of the DAC, the full scale output voltage (or current) could be digitally programmed over a wide range with 8 bits of resolution. Likewise, the full scale input voltage of an ADC could be programmed which could be used in place of a programmable gain amplifier (PGA).

The circuit shown in Figure 10 demonstrates using the ISL21400 to program the full scale output current of a high speed 260MHz, 12-bit ISL5857 DAC over the recommended output current operating range of 2mA to 20mA; operation below 2mA is possible with performance degradation. In this example, the temperature slope is fixed at zero by setting $M = 128$, but it could be adjusted if desired depending on the needs of the application.

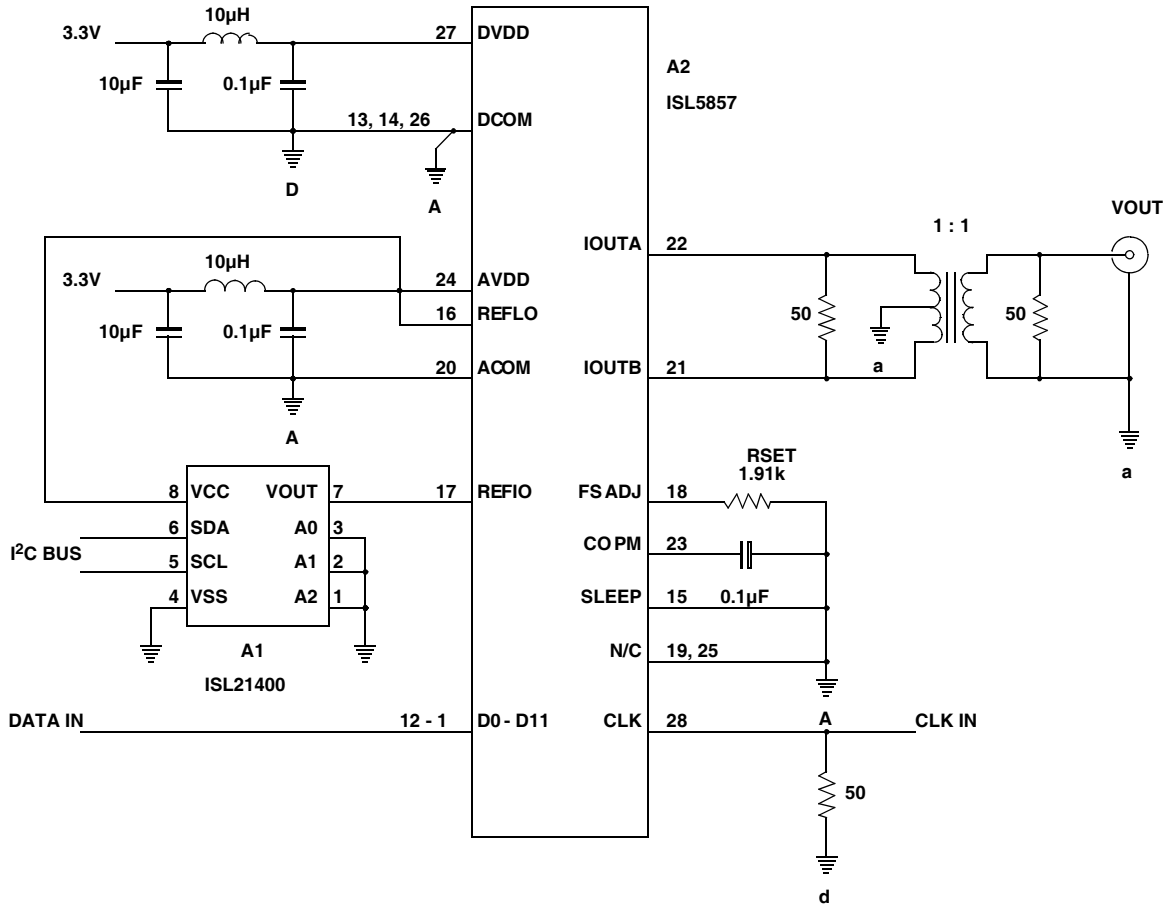

FIGURE 10.

By biasing REFLO to A_{VDD} , the ISL5857 internal reference voltage is disabled, and the ISL21400 output voltage (N-register value) connected to REFIO determines the full scale output current (IFS) at I_{OUTA} and I_{OUTB} .

$$IFS = V_{REFIO} / R_{set} * 32$$

Setting $M = 128$ for zero temperature slope,

$$ISL21400 \text{ output voltage, } V_{OUT} = AV * 1.2 * N/255$$

Setting $AV = 1$,

$$ISL21400 \text{ output voltage, } V_{OUT} = 1.2 * N/255$$

$$IFS = 1.2 * N * 32 / (255 * R_{set})$$

$$IFS = 0.15 * N / R_{set}$$

In this example with $N = 255$, $R_{set} = 1.91k\Omega$

$$IFS = 20mA$$

For 2mA full scale output current, $N = 2mA * 1.91k/0.15$

$$N = 25$$

Sealed Lead Acid (SLA) Battery Charging Temperature Compensation

A circuit that is set for the maximum allowable charge voltage, but has a constant current limit to control the initial absorption current can produce a very nice charger. This type of charger can both charge at a reasonable rate and maintain the battery at full charge without damage. However, the maximum voltage following the constant charge current is a function of temperature. A temperature compensated charger is a little more expensive, and should be used where the temperature varies significantly from room temperature. The ISL21400 can be used to program both the charger type (Cyclic Use or Standby Use) and the temperature compensation as shown in the following section, "Temperature Sensor with Programmable Custom Scaling" on page 14. It must be noted that this section describes the temperature compensated maximum allowable charge voltage for a general purpose voltage regulator with either a linear regulator or switching regulator. The constant charge current circuit is not shown in this section, and would need to be included for a complete SLA battery charger.

Application Note 1446

Table 11 is taken from data for a 12V SLA battery from Applications Information shown on the PowerStream web site; www.powerstream.com.

TABLE 11.

BATTERY TEMPERATURE (°C)	CHARGE VOLTAGE (V)	
	CYCLIC USE	STANDBY USE
0	15.30 to 15.90	13.80 to 14.10
10	14.94 to 15.54	13.68 to 13.98
20	14.58 to 15.18	13.56 to 13.86
25	14.40 to 15.00	13.50 to 13.80
30	14.22 to 14.82	13.44 to 13.74
40	13.86 to 14.46	13.32 to 13.62
50	13.50 to 14.10	13.20 to 13.50

Plotting the midpoint of each Battery Charging Voltage and calculating the slope (dV/dT) for each battery use:

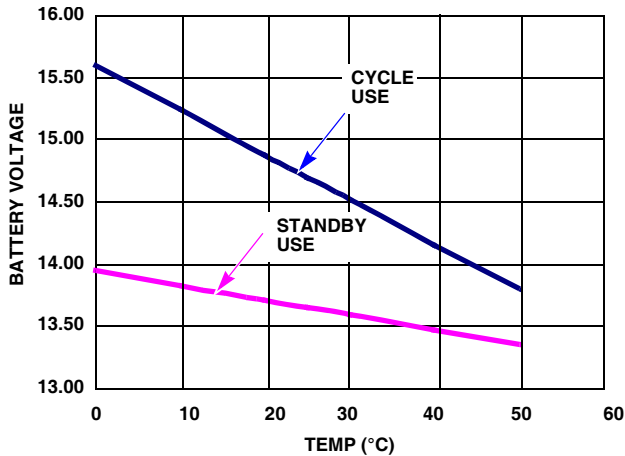

FIGURE 11. 12V SLA BATTERY CHARGING vs TEMPERATURE

TABLE 12.

BATTERY USE	dv/dt (mV/°C)	BATTERY CHARGING VOLTAGE
Cycle Use	36	$V_{BAT} = 14.70 - 36\text{mV}/^{\circ}\text{C} * (T - 25^{\circ}\text{C})$
Standby Use	12	$V_{BAT} = 13.65 - 12\text{mV}/^{\circ}\text{C} * (T - 25^{\circ}\text{C})$

Assuming a general purpose voltage feedback loop typical of a linear or switching regulator with the ISL21400, refer to Figure 12.

Note: Figure 12 only shows the voltage regulation loop; there must be an additional charging current control loop.

Summing currents:

$$(V_{BAT} - V_{REF})/R1 + (0 - V_{REF})/R2 + (Vx - V_{REF})/R3 = 0 \text{ (EQ. 21)}$$

Solving for V_{BAT} :

$$V_{BAT} = V_{REF} * (1 + R1/R2 + R1/R3) - Vx * R1/R3 \text{ (EQ. 22)}$$

Let's assume that the charge must be programmable for either Cycle Use charging or Standby Use charging for a 12V SLA battery.

Set R1 and R2 for 14 V which is approximately midpoint between the two +25 °C charging voltages. The actual +25°C battery voltage will be programmed with the ISL21400 via the N register value.

If $V_{REF} = 1.2\text{V}$, and we let $R2 = 10\text{k}$, then $R1 = 107\text{k}$ for a 14V battery voltage.

To determine the value for the ISL21400 output voltage, Vx :

$$Vx = [V_{REF} * (1 + R1/R2 + R1/R3) - V_{BAT}] * R3/R1 \text{ (EQ. 23)}$$

Let $R3 = 5\text{k}$ (general approximation)

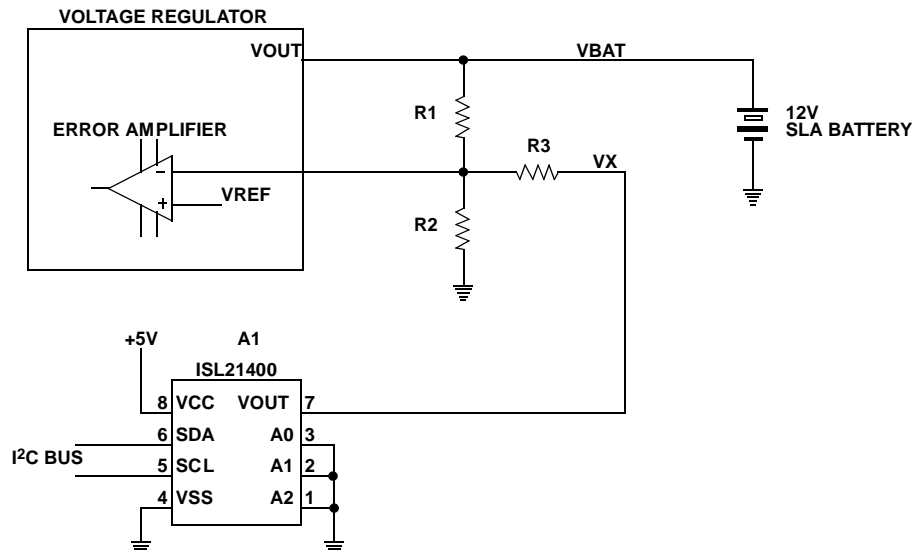

FIGURE 12.

For $V_{BAT} = 14.70V$ at $+25^{\circ}C$ (Cycle use charging),
 $V_x = 1.169V$

For $V_{BAT} = 13.65V$ at $+25^{\circ}C$ (Standby use charging),
 $V_x = 1.216V$

To determine the ISL21400 N register value:

ISL21400 output voltage $V_x = AV * 1.2 * N/255$

Set $AV = 2$ since the ISL21400 output voltage must be greater than 1.2V

For $V_x = 1.169$, $N = 124$ (Cycle use charging)

For $V_x = 1.218$, $N = 129$ (Standby use charging)

To determine the ISL21400 M register value:

$$V_{BAT} = V_{REF} * (1 + R1/R2 + R1/R3) - V_x * R1/R3$$

$$dV_{BAT}/dT = -dV_x/dT * R1/R3$$

Solving for dV_x/dT :

$$dV_x/dT = -dV_{BAT}/dT * R3/R1$$

For Cycle Use charging, $dV_{BAT}/dT = 36mV/^{\circ}C$

$$dV_x/dT = -(36mV/^{\circ}C) * 5k/107k = -1.682mV/^{\circ}C$$

$$ISL21400 \text{ output voltage, } dV_x/dT = AV * (-2.1mV/^{\circ}C) * (2M - 255)/255$$

$$-1.682mV/^{\circ}C = 2 * (-2.1mV/^{\circ}C) * (2M - 255)/255$$

$$M = 179$$

For Standby Use charging, $dV_{BAT}/dT = 12mV/^{\circ}C$

$$dV_x/dT = -(12mV/^{\circ}C) * 5k/107k = .561mV/^{\circ}C$$

$$ISL21400 \text{ output voltage, } dV_x/dT = Av * (-2.1mV/^{\circ}C) * (2M - 255)/255$$

$$-0.561mV/^{\circ}C = 2 * (-2.1mV/^{\circ}C) * (2M - 255)/255$$

$$M = 145$$

TABLE 13. SUMMARY TABLE

BATTERY USE	VBAT @ +25°C	dV/dT (mV/°C)	AV	N REGISTER	M REGISTER
Cycle Use	14.70	36	2	124	179
Standby Use	13.65	12	2	129	145

Temperature Sensor with Programmable Custom Scaling

Often it is necessary to generate an output voltage based on a linear relationship between two fixed points for output voltage vs temperature; i.e., V_{OUT1} at $T1$, V_{OUT2} at $T2$. This is easily accomplished with the ISL21400 by applying the following technique and solving two simultaneous equations for N and M values.

1. General Electric product catalog, Dec. 31, 1962

$$V_{OUT1} = AV * V_{REF} * (N/255) + AV * V_S * (T_1 - 25) * (2M - 255)/255 \quad (EQ. 24)$$

$$V_{OUT2} = AV * V_{REF} * (N/255) + AV * V_S * (T_2 - 25) * (2M - 255)/255 \quad (EQ. 25)$$

For example, suppose your Turboencabulator¹ project requires temperature compensation for the flux gate capacitors required to stabilize the unilateral phase detectors. Due to the extreme difficulty of obtaining the flux gate capacitor, three vendors are selected to assure production inventory. However, each vendor's flux gate capacitor requires a much different compensating voltage as shown in the following Summary table.

TABLE 14. SUMMARY TABLE

VENDOR	V _{OUT1} at	T1 (°C)	V _{OUT2} at	T2 (°C)
MaxCap	0.75	+25	1.15	+75
Fox Capacitors	2.15	+25	2.50	+75
I2CGet	3.765	+25	4.000	+75

The Intersil ISL21400, Programmable Temperature Slope Voltage Reference can easily be used to provide a programmable compensation voltage for the flux gate capacitor that can be programmed via the I²C bus for each of the vendors shown in Table 14.

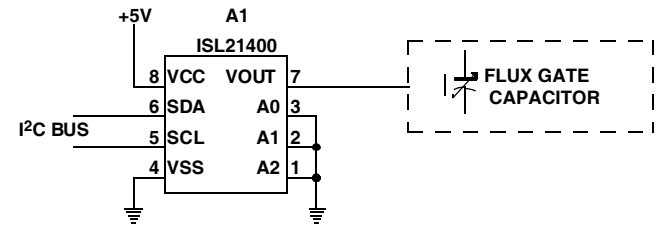

FIGURE 13.

For the MaxCap flux gate capacitor, the values for V_{OUT1} , $T1$, V_{OUT2} , and $T2$ can be inserted into the Equations 24 and 25.

$$0.75 = AV * V_{REF} * (N/255) + AV * V_S * (25 - 25) * (2M - 255)/255 \quad (EQ. 26)$$

$$1.15 = AV * V_{REF} * (N/255) + AV * V_S * (75 - 25) * (2M - 255)/255 \quad (EQ. 27)$$

where

$$AV = 4$$

$$V_{REF} = 1.200V$$

$V_s = -2.1\text{mV}$

Solving these equations simultaneously either by hand calculations or a math solving program (MathCAD, TK Solver) shows that $N = 39.8$ and $M = 6.07$ such that:

$N = 40$ and $M = 6$ (Integer values)

Applying the same calculations for the other flux gate capacitor vendors yields the Table 15 for the N and M values.

TABLE 15. SUMMARY TABLE

VENDOR	V _{OUT1} at	T1 (°C)	V _{OUT2} at	T2 (°C)	N	M
MaxCap	0.75	+25	1.15	+75	40	6
Fox Capacitors	2.15	+25	2.50	+75	114	21
I ² CGet	3.765	+25	4.000	+75	200	56

Voltage Regulator Output Voltage Programming

Often it desirable to design a programmable voltage regulator such that its output voltage and output voltage temperature slope can be adjusted under software control. A common application is a multiplexed LCD display where temperature has an important effect in the variation of threshold voltage, as shown in Figure 14.

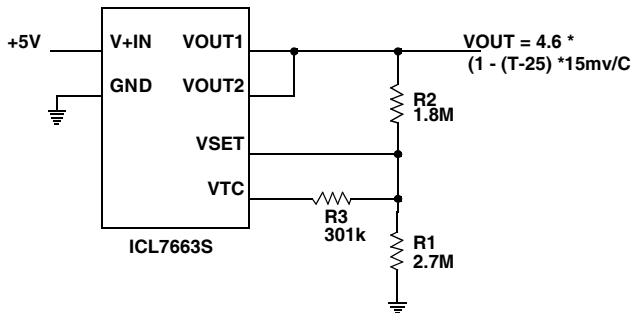

FIGURE 14.

From the ICL7663S data sheet Equation 1 and 2:

$$V_{OUT} = V_{SET} * (1 + R2/R1) + R2/R3 * (V_{SET} - V_{TC})$$

$$V_{OUT} = 1.3 * (1 + 1.8\text{M}/2.7\text{M}) + 1.8\text{M}/300\text{k} * (1.3 - V_{TC}) \quad \text{(EQ. 28)}$$

$$V_{OUT} = 10 - 6 * V_{TC}$$

Where V_{TC} is .9V with a temperature coefficient of +2.5 mV/C so that:

$$V_{TC} = 0.9 * (1 + (T - 25) * 2.5\text{mV/C}) \quad \text{(EQ. 29)}$$

$$V_{OUT} = 10 - 6 * .9 * (1 + (T - 25) * 2.5\text{mV/C}) \quad \text{(EQ. 30)}$$

$$V_{OUT} = 4.6 * (1 + (T - 25) * 15\text{mV/C})$$

The drawback of this circuit is that the output voltage and temperature coefficient is fixed by resistor values, and there is no way to program the output voltage.

The circuit shown below adds the ISL21400 to provide temperature sensing and the ability to program both the output voltage and temperature coefficient with the I²C bus such that:

$$V_{OUT} = V_{SET} * (1 + R2/R1) + R2/R3 * (V_{SET} - V_X)$$

$$\text{where } V_X = A_v * V_{REF} * (N/255) + A_v * V_S * (T-25) * (2\text{M} - 255) / 255 \quad \text{(EQ. 31)}$$

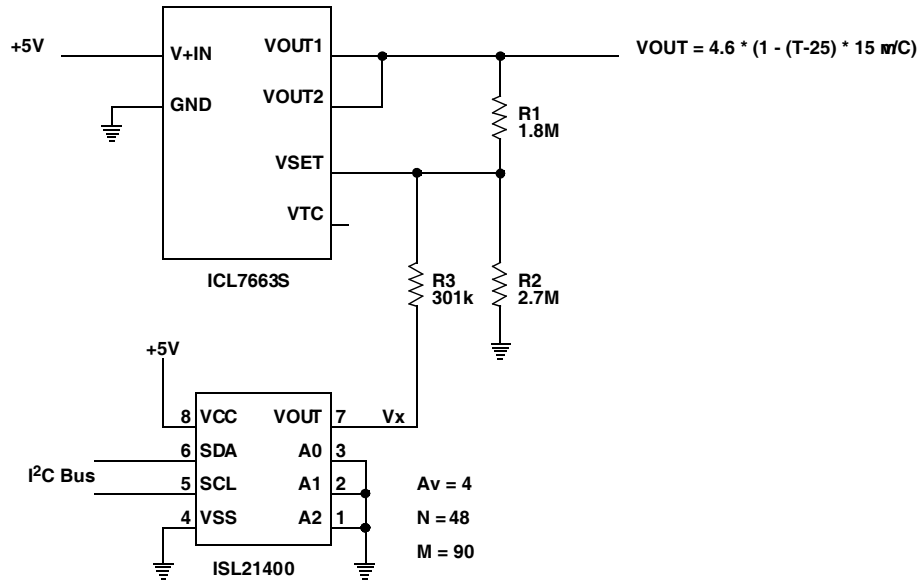

FIGURE 15.

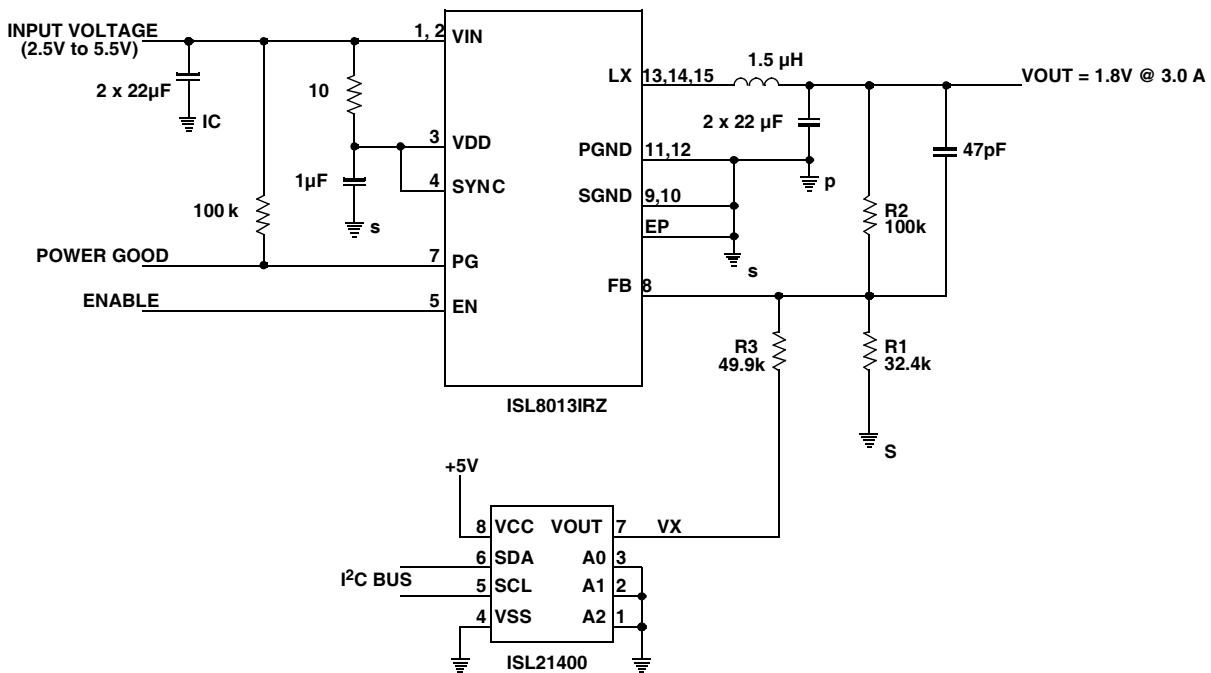

FIGURE 16.

In Figure 15, the V_{TC} output is replaced by the ISL21400, and with the N and M values shown, is identical to the ICL7663S V_{TC} output. However, the output voltage can be programmed over a range of 1.3V to 10.0V (Note: The V+IN voltage supply must be increased to >10.5V), and the temperature coefficient programmed up to $\pm 50\text{mV/C}$ by programming the N and M values of the ISL21400.

This concept can be applied at any voltage regulator by summing the output voltage (V_x) from the ISL21400 into the feedback summing node with a resistor (R3). Figure 16 uses the ISL21400 to set the output voltage via the I²C bus of a ISL8013, 3A switching regulator, from 1.20V to 3.3V as shown in Table 16.

TABLE 16.

V _{OUT}	A _V	N	M
3.3	1	161	128
2.5	1	251	128
1.8	2	158	128
1.5	2	175	128
1.2	2	192	128

NOTE: Since this is an open loop application, in Table16, the N values have been adjusted to account for the ISL21400 non-zero output voltage, as described in Appendix A. For additional accuracy, production test measurements can be used to determine a final N value; at most this might require a ±1 change in the N value.

Appendix A

Improving Accuracy in Open-Loop Applications

The ISL21400 exhibits a non-zero output voltage at N = 0 due to the output amplifier saturation voltage and input offset voltage. Lab measurements have shown the output voltage at N = 0 to be 76mV, 110mV, and 191mV at Av = 1, 2, and 4. A simple circuit model of the output at N = 0 can be described by the following equation:

$$V_{OS} = V_{SAT} + V_0 * A_v$$

where V_{SAT} is the output amplifier saturation voltage; approximately 38mV V₀ is the offset voltage of the output amplifier, DAC, and summer circuit; approximately 38mV.

The graph in Figure 17 shows the ISL21400 output voltage, V_{OUT}, vs Code In; notice the output voltage VOS (76mV) at N = 0.

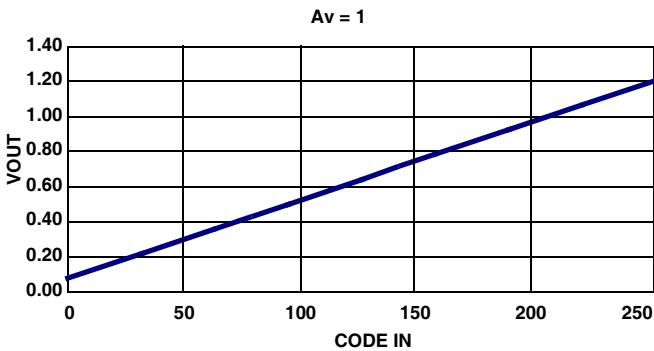

FIGURE 17. EFFECT OF ZERO CORRECTION, AV=1

The basic equation for the ISL21400 output voltage is:

$$V_{OUT} = A_V * 1.2 * (N/255) + A_V * (-2.1 \text{ mV/}^\circ\text{C}) * (T - 25) * (2M - 255) / 255 \quad (\text{EQ. 32})$$

This equation can be modified to include the effect of VOS by adding it to the V_{OUT} equation.

$$V_{OUT} = (V_{SAT} + A_V * V_0) + (A_V * V_{REF} - V_{SAT} - A_V * V_0) * N / 255 \quad (\text{EQ. 33})$$

The graph in Figure 18 shows the error in the ISL21400 output voltage with the standard V_{OUT} equation and the modified V_{OUT} equation.

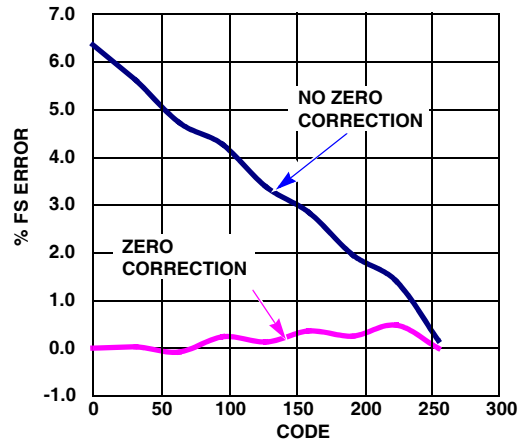

FIGURE 18.

To demonstrate the advantage of applying the zero correction to a real circuit, the ISL21400 was connected to a linear voltage regulator to program its output voltage over a range of 1.20V to 5.0V as shown in Figure 19 with M = 128.

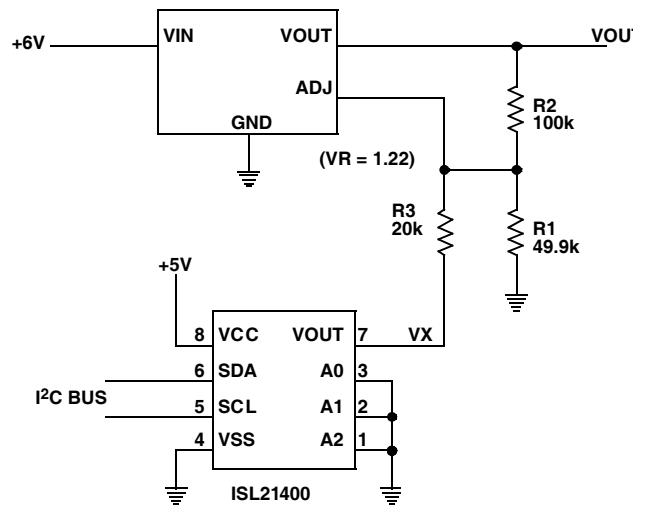

FIGURE 19.

Where:

V_{OUT} Desired is the desired output voltage

A_V is the ISL21400 programmed gain

N is the programmed N value with no zero correction applied

N_{ADJ} is the programmed N value with zero correction applied

V_{OUT} Actual is the measured output voltage from the regulator.

It is interesting to note that the slight output voltage error is a result of the quantizing error due to the integer values of N ; i.e., for a 2.5V output, the calculated value for N is 149.4 that must be rounded down to the integer value of 149.

Intersil Corporation reserves the right to make changes in circuit design, software and/or specifications at any time without notice. Accordingly, the reader is cautioned to verify that the Application Note or Technical Brief is current before proceeding.

For information regarding Intersil Corporation and its products, see www.intersil.com
